



**GeKaMac®**



# **PoWer SAW 1000 AC / DC (TANDEM)**

## **Users Manual**

Please Read and Understand This Manual  
Before Operating The Welding Machine

This machine is for internal use only.

It complies with the WEEE Directive.

This machine has been designed in accordance with the EN 60974-1 and EN 60974-10 standards.

The machine is safe when installation, operation, and maintenance are performed in accordance with the user manual and regulations. The operator and machine owner are responsible for adhering to safety rules.

Gedik Kaynak San. Ve Tic. A.Ş. assumes no responsibility for safety or CE compliance if any modifications are made to the machine or if safety rules are not followed.



**This Class A equipment is not suitable for use in homes and similar residential areas where the power supply is provided by the low-voltage public electricity network.**



This machine is not household waste and cannot be disposed of in the trash.

When the machine reaches the end of its service life or becomes obsolete, it must be disposed of in accordance with regulations.

**COMPLIES WITH THE WEEE DIRECTIVE.**

### **Eco Design Statement**

This machine has been designed and manufactured in accordance with the requirements of the 2009/125/EC Eco Design Directive concerning the environmentally friendly design of energy-related products.

Accordingly, machines with an idle mode are as follows.

	<b>Idle Mode</b>
<b>MMA</b>	<b>X</b>
<b>MIG</b>	√
<b>TIG</b>	√
<b>Plazma</b>	√
<b>SAW</b>	<b>Out of Scope</b>

**Efficiency measurements should be conducted only on the power unit. The water cooling system should be disabled. For more information on measurements and machine settings, Gedik Kaynak Sanayi ve Ticaret A.Ş. should be consulted.**

## Dear Customer

This instruction manual will help you get to know your new machine. Read the manual carefully and you will soon be familiar with all the many great features of your new product. Meanwhile, please remember well safety rules and operate as instruction.

If you treat your product carefully, this definitely helps to prolong its enduring quality and reliability—things which are both essential prerequisites for getting outstanding results.

Production specification may change without advance notice.

The model you purchase is :

**PoWer SAW 1000 ACDC (TANDEM)**

Please find corresponding models from the "Contents".

**Important:**

Please take special note of safety rules and operate as instruction in case of damage and serious injury.

## Safety Rules



“**Danger**” indicates an imminently hazardous situation which, if not avoided, will result in death or serious injury.



“**Warning!**” indicates a possible hazardous situation which, if not avoided, could result in death or serious injury. The possible hazards are explained in the text.



“**Caution**” indicates a possible hazardous situation which, if not avoided, may result in slight or moderate injury.



“**Note!**” indicates a situation which implies a risk of impaired welding result and damage to the equipment.

“**Important!**” indicates practical tips and other useful special message. It is no signal word for a harmful or dangerous situation.



### Utilization for intended purpose only

- The machine may only be used for jobs as defined by the “Intended purpose”.
- Utilization for any other purpose, or in any other manner, shall be deemed to be “not in accordance with the intended purpose”. The manufacturer shall not be liable for any damage resulting from such improper use.



### Safety signs

- All the safety instructions and danger warnings on the machine must be kept in legible condition, not removed, not be covered, pasted or painted cover.



### Safety inspection

- The owner/operator is obliged to perform safety inspection at regular intervals.
- The manufacturer also recommends every 3-6 months for regular maintenance of power sources.



### Electric shock can kill

- Touching live electrical parts can cause fatal shocks or severe burns. The electrode and work circuit is electrically live whenever the output is on. The input power circuit and machine internal circuits are also live when power is on. In MIG/MAG welding, the wire, drive rollers, wire feed housing and all metal parts touching the welding wire are electrically live. Incorrectly installed or improperly grounded equipment is a hazard.
- Do not touch live electrical parts of the welding circuit, electrodes and wires with your bare skin or wet clothing.
- The operator must wear dry hole-free insulating welding gloves and body protection while performs the welding.
- Insulate yourself from work and ground using dry insulating protection which is large enough to prevent you full area of physical contact with the work or ground.
- Connect the primary input cable according to rules. Disconnect input power or stop machine before installing or maintenance.
- If welding must be performed under electrically hazardous conditions as follow: in damp locations or wearing wet clothing; on metal structures such as floors, gratings, or scaffolds; when in cramped positions such as sitting, kneeling, or lying; or in occasion when there is a high risk of unavoidable or accidental contact with the work piece or ground. Must use additional safety precautions: semiautomatic DC constant voltage (wire) welder, DC manual (Stick) welder and AC welder with reduced open-load voltage.
- Maintain the electrode holder, ground clamp, welding cable and welding machine in good, safe operating condition. Replace damaged part immediately.



### Electric and magnetic fields (EMF) may be dangerous

- If electromagnetic interference is found to be occurring, the operator is obliged to examine any possible electromagnetic problems that may occur on equipment as follow:
  - mains, signal and data-transmission leads
  - IT and telecoms equipment
  - measurement and calibration devices
  - Wearers of pacemakers
- Measures for minimizing or preventing EMC problems:
  - Mains supply

If electromagnetic interference still occurs, despite the fact that the mains connection in accordance with the regulations, take additional measures

- Welding cables

Keep these as short as possible

Connect the work cable to the work piece as close as possible to the area being welded.

Lay term well away from other cables.

Do not place your body between your electrode and work cables.

- Equipotential bonding
- Workpiece grounding (earthing)
- Shielding

Shield the entire welding equipment and other equipment nearby.

### **ARC rays can burn**



- Visible and invisible rays can burn eyes and skin.
- Wear an approved welding helmet or suitable clothing made from durable flame-resistant material (leather, heavy cotton, or wool) to protect your eyes and skin from arc rays and sparks when welding or watching.
- Use protective screens or barriers to protect other nearby personnel with suitable, non-flammable screening and/or warn them not to watch the arc nor expose themselves to the arc rays or to hot spatter or material.

### **Fumes and gases can be dangerous**



- Welding may produce fumes and gases, breathing these fumes and gases can be hazardous to your health.
- When welding, keep your head out of the fume. If inside, ventilate the area at the arc to keep fumes and gases away from the breathing zone. If ventilation is not good, wear an approved air-supplied respirator.
- Work in a confined space only if it is well ventilated, or while wearing an air-supplied respirator.
- Welding fumes and gases can displace air and lower the oxygen level causing injury or death. Always use enough ventilation, especially in confined areas, to insure breathing air is safe.

### **Welding and cutting sparks can cause fire or explosion**



- When not welding, make sure the electrode circuit is not touching the work or ground. Accidental contact can cause sparks, explosion, overheating, or fire. Make sure the area is safe before doing any welding.
- Welding and cutting on closed containers, such as tanks, drums, or containers, can cause them to blow up. Make sure proper steps have been taken.
- When pressure gas is used at the work site, special precautions are required to prevent hazardous situations.
- Connect work cable to the work as close to the welding zone as practical to prevent welding current from passing too long and creating fire hazards or overheat.
- Wear oil-free protective garments such as leather gloves, heavy shirt, cuffless trousers, high shoes, and a cap. Wear ear plugs when welding out of position or in confined places. Always wear safety glasses with side shields when in a welding area.
- Be attention that welding sparks and hot materials from welding can easily go through small cracks and openings to adjacent areas and start a fire. Remove fire hazardous from the welding area, if not possible, cover them thoroughly. Do not weld where flying sparks can strike flammable material and where the atmosphere may contain flammable dust, gas, or liquid vapors (such as gasoline).
- Protect yourself and others from flying sparks and hot metal. Remove any combustibles from operator before perform any welding.
- Keep a fire extinguisher readily available.
- Empty containers, tanks, drums, or pipes which have combustibles before perform welding.
- Remove stick electrode from electrode holder or cut off welding wire at contact tip when not in use.
- Apply correct fuses or circuit breakers. Do not oversize or bypass them.

### **Cylinder can explode if damaged**



- Pressure gas cylinders contain gas under high pressure. If damaged, a cylinder can explode. Since gas cylinders are normally part of the welding process, be sure to treat them carefully.
- Cylinders should be located away from areas where they may be struck or subjected to physical damage. Use proper equipment, procedures, and sufficient number of persons to lift and move cylinders.
- Always install cylinders in an upright position by securing to a stationary support or cylinder rack to prevent falling over or tipping.
- Keep a safe distance from arc welding or cutting operations and any other source of heat, sparks, or flame.
- No touching cylinder by welding electrode, electrode holder or any other electrically "hot" parts. Do not drape welding cables or welding torches over a gas cylinder.
- Use only correct compressed gas cylinders, regulators, hoses, and fittings designed for the process used; maintain them and associated parts in good condition.
- Use only compressed gas cylinders containing the correct shielding gas for the and properly operating regulators designed for the gas and pressure used. All hoses, fittings, etc. should be suitable for the application and maintained in good condition.
- Open the cylinder valve slowly and keep your head and face away from the cylinder valve outlet.
- Valve protection caps should be kept in place over valve except when the cylinder is in use or connected for use.



### Hot parts can burn

- Do not touch hot parts with bare hand or skin.
- Ensure equipment is cooled down before perform any work.
- If touching hot parts is needed, use proper tools and/or wear heavy, insulated welding gloves and clothing to prevent burns.



### Flying metal or dirt can injure eyes

- When welding, chipping, wire brushing, and grinding can cause sparks and flying metal. It can hurt your eyes.
- Remember wear appropriate safety glasses with side shields when in welding zone, even under your welding helmet.



### Noise can damage hearing

- Noise from some processes or equipment can damage hearing.
- Remember wear approved ear protection to protect ears if noise level is high.



### Moving parts can injure

- Stay away from moving parts such as fans.
- Stay away from pinch points such as drive rolls.
- Keep all doors, panels, covers, and guards closed and securely in place.
- Have only qualified persons remove doors, panels, covers, or guards for servicing and maintenance.
- Reinstall doors, panels, covers, or guards when servicing and maintenance is finished and before reconnecting input power.



### Overuse can cause overheating

- Use machine follow duty cycle. Reduce current or reduce duty cycle before starting to weld again.
- Allow cooling period.
- Do not block or filter airflow to unit.



### Static can damage PCB

- Always wear wrist straps before touching PCB or parts.
- Use proper static-proof bags and package to store or move PCB.



### Safety markings

- Equipment with CE-markings meets the basic requirements of the Low-Voltage and Electromagnetic Compatibility Guideline (e.g., relevant product standards according to EN 60974).



### Safety markings

- The equipment with the CCC mark meets the basic requirements stipulated in the Chinese standards GB / T15579.1-2013 and GB / T8118.



### Safety markings

- This marking means that the product is certified for both the U.S. and Canadian markets, to the applicable U.S. and Canadian standards. The preferred location of the indicators is as shown.

## Les règles de sécurité



“**Danger**” indique une situation dangereuse imminente qui, si elle n'est pas évitée, entraînera la mort ou des blessures graves.



“**Alerte!**” Indique une situation dangereuse possible qui, si elle n'est pas évitée, pourrait entraîner la mort ou des blessures graves. Les risques possibles sont expliqués dans le texte.



“**Attention**” indique une situation dangereuse qui, si elle n'est pas évitée, peut entraîner des blessures légères ou modérées.



“**Note!**” indicates a situation which implies a risk of impaired welding result and damage to the equipment.

“**Important!**” indique des conseils pratiques et d'autres messages spéciaux utiles. Ce n'est pas un mot d'avertissement pour une situation nuisible ou dangereuse.



### Utilisation uniquement pour le but prévu. La machine ne peut être utilisée

- que pour les travaux définis par «Objet prévu». L'utilisation à d'autres fins, ou
- de toute autre manière, est réputée "non conforme à l'objectif prévu". Le
- fabricant ne sera pas responsable des dommages résultant d'une utilisation

- inappropriée.



**Panneaux de sécurité.** Toutes les consignes de sécurité et les

- avertissements de danger sur la machine doivent être conservés dans un état
- lisible, non enlevé, ne pas être recouvert, collé ou peint.



**Inspection de sécurité. Le propriétaire / l'opérateur est obligé d'effectuer**

- une inspection de sécurité à intervalles réguliers. Le fabricant recommande
- également tous les 3-6 mois pour la maintenance régulière des sources
- d'alimentation.



**Le choc électrique peut tuer**

- Toucher les pièces en direct peut causer des chocs électriques mortels ou des brûlures graves. Lorsque la machine est allumée, l'électrode et le circuit de masse sont électriquement en direct. Le circuit de puissance d'entrée et les circuits internes de la machine sont également en direct lorsque l'entrée est activée. Dans le soudage MIG / MAG, le fil, les rouleaux d'entraînement, le boîtier d'alimentation en fil et toutes les pièces métalliques qui touchent le fil de soudure sont électriquement en direct. Des équipements incorrectement installés ou mal branchés peuvent constituer un danger.
- Ne touchez pas les parties actives du circuit de soudage, les électrodes et les fils avec votre peau nue ou vos vêtements humides.
- L'opérateur doit porter des gants de soudage isolés sans trous secs et une protection du corps tout en effectuant le soudage.
- Éliminez-vous du travail et du sol en utilisant une protection isolante sèche qui peut être suffisamment couverte pour vous empêcher de toucher complètement le contact physique avec le sol ou le sol..
- Connectez le câble d'entrée principal selon les règles. Débranchez l'alimentation d'entrée ou la machine d'arrêt avant l'installation ou la maintenance.
- Si le soudage doit être effectué dans des conditions électriquement dangereuses comme suit: dans des endroits humides ou portant des vêtements humides; sur des structures métalliques telles que des planchers, des grilles ou des échafaudages; quand il se trouve à des positions étroites telles que assis, agenouillé ou couché; ou en cas de risque élevé de contact inévitable ou accidentel avec la pièce ou le sol. Doit utiliser des précautions de sécurité supplémentaires: soudeur de tension constante (fil) semiautomatique, soudage manuel DC (Stick) et soudeuse à courant alternatif avec tension de charge réduite.
- Tout travail de maintenance doit être effectué dans un état bon et sûr. Une fois trouvé, la pièce endommagée doit être réparée ou remplacée immédiatement.



**Les champs électriques et magnétiques (EMF) peuvent être dangereux**

- Si des perturbations électromagnétiques se produisent, l'opérateur est obligé d'examiner les éventuels problèmes électromagnétiques pouvant survenir sur l'équipement comme suit:
  - Mines, signaux et transmission de données
  - Matériel informatique et télécom
  - Appareils de mesure et d'étalonnage
  - Porteurs de pacemakers
- Mesures pour minimiser ou prévenir les problèmes de compatibilité électromagnétique:
  - Alimentation secteur
- Si des interférences électromagnétiques se produisent encore, malgré le fait que la connexion secteur conformément à la réglementation, prendre des mesures supplémentaires
  - Câbles de soudure
- Gardez ces aussi courts que possible.
- Connectez le câble de travail à la pièce de travail le plus près possible de la zone soudée.
- Collez-les bien loin des autres câbles.
- Ne placez pas votre corps entre votre électrode et vos câbles de travail:
  - Collage équipotentiel
  - Mise à la terre de la pièce (mise à la terre)
  - Blindage
- Boucler l'ensemble de l'équipement de soudage et d'autres équipements à proximité

**Les rayons ARC peuvent brûler**



- Les rayons visibles et invisibles des processus de soudure peuvent brûler les yeux et la peau.
- Toujours porter un casque de soudage approuvé ou des vêtements appropriés en matériau résistant à la flamme durable (cuir, coton lourd ou laine) pour protéger vos yeux et votre peau des rayons d'arc et des étincelles lors du soudage ou de l'observation.
- Toujours utiliser des écrans de protection ou des barrières pour protéger d'autres membres du personnel à proximité avec un dépistage approprié et non inflammable et / ou les avertir de ne pas regarder l'arc, ni se exposer aux rayons d'arc ou aux spatters ou aux matières chaudes.



Les fumées et les gaz peuvent être dangereux

- La soudure peut produire des fumées et des gaz, la respiration de ces fumées et des gaz peut être dangereuse pour votre santé.
- Lors du soudage, retirez la tête de la fumée. Si à l'intérieur, ventiler la zone à l'arc pour éviter les fumées et les gaz de la zone de respiration. Si la ventilation n'est pas bonne, portez un respirateur approuvé à l'air..
- Travailler dans un espace confiné seulement s'il est bien ventilé, ou en portant un respirateur fourni par l'air.
- Les vapeurs et les gaz de soudure peuvent déplacer l'air et abaisser le niveau d'oxygène causant des blessures ou la mort. Toujours utiliser une ventilation suffisante, en particulier dans les zones confinées, pour assurer l'air respirant est sûr.



**Les étincelles de soudure et de coupe peuvent provoquer un incendie ou une explosion**

- Lors de la soudure, assurez-vous que le circuit de l'électrode ne touche pas le travail ou le sol. Un contact accidentel peut provoquer des étincelles, une explosion, une surchauffe ou un incendie. Assurez-vous que la zone est sûre avant toute soudure.
- La soudure et la découpe sur des conteneurs fermés, tels que des réservoirs, des bidons ou des conteneurs, peuvent les faire exploser. Assurez-vous que les étapes appropriées ont été prises.
- Lorsque des gaz sous pression sont utilisés sur le chantier, des précautions particulières sont nécessaires pour prévenir les situations dangereuses.
- Connectez le câble de travail au travail aussi près de la zone de soudure que possible pour éviter que le courant de soudure ne passe trop longtemps et crée des risques d'incendie ou une surchauffe.
- Portez des vêtements de protection sans huile tels que des gants en cuir, une chemise lourde, un pantalon sans manchette, des chaussures hautes et un capuchon. Portez des bouchons d'oreille lors du soudage hors position ou dans des endroits confinés. Toujours porter des lunettes de sécurité avec des protections latérales dans une zone de soudure.
- Soyez attentif à ce que les étincelles de soudage et les matériaux chauds provenant de la soudure puissent facilement passer par de petites fissures et des ouvertures dans les zones adjacentes et déclencher un incendie. Retirez le feu dangereux de la zone de soudure, si possible, les couvrir complètement. Ne pas souder lorsque les étincelles volantes peuvent enfoncer des matériaux inflammables et où l'atmosphère peut contenir des vapeurs inflammables, des gaz ou des liquides (comme de l'essence).
- Protégez-vous et les autres d'étincelles volantes et de métal chaud. Enlevez les combustibles de l'opérateur avant d'effectuer toute soudure.
- Gardez un extincteur facilement disponible.
- Récipients, réservoirs, bidons ou tuyaux vides qui ont des combustibles avant de procéder au soudage..
- Enlevez l'électrode du porte-électrode ou coupez le fil de soudage à la pointe de contact lorsqu'il n'est pas utilisé.
- Appliquez les fusibles ou les disjoncteurs corrects. Ne les surdimensionnez pas ou ne les contournez pas.



**Le cylindre peut exploser s'il est endommagé**

- Les bouteilles comprimées sont des récipients à haute pression. Un mauvais fonctionnement peut provoquer une explosion des cylindres. Étant donné que les bouteilles de gaz font normalement partie du procédé de soudage, faites attention de les traiter.
- Les cylindres doivent être situés à l'écart des zones où ils peuvent être frappés ou soumis à des dommages physiques. Utiliser l'équipement approprié, les procédures et un nombre suffisant de personnes pour soulever et déplacer des cylindres.
- Toujours garder les cylindres dans une position verticale en se fixant sur un support stationnaire ou un support de cylindre pour éviter de tomber ou de basculer.
- Gardez une distance sûre des opérations de soudage à l'arc ou de coupe et toute autre source de chaleur, des étincelles ou des flammes.
- Pas de cylindre touchant par électrode de soudure, support d'électrode ou toute autre partie électriquement "chaude". Ne pas draguer des câbles de soudure ou des torches de soudage sur une bouteille de gaz.
- Utiliser uniquement des bouteilles, des régulateurs, des tuyaux et des raccords de gaz comprimés conçus pour le procédé utilisé, les maintenir et les pièces associées en bon état..
- Utiliser uniquement des bouteilles de gaz comprimés contenant le bon gaz de protection pour les régulateurs de fonctionnement appropriés conçus pour le gaz et la pression utilisés. Tous les tuyaux, raccords, etc. devraient être adaptés à l'application et maintenus en bon état.
- Ouvrez lentement la soupape de la bouteille et gardez votre tête et votre visage éloignés de la sortie de la soupape du cylindre.
- Les capuchons de protection de la soupape doivent être maintenus en place sur la vanne prévue lorsque le cylindre est utilisé ou connecté.





### **Les pièces chaudes peuvent brûler**

- Ne touchez pas les pièces chaudes avec la main nue ou la peau.
- Assurez-vous que l'équipement est refroidi avant d'effectuer tout travail.
- Si des pièces chaudes en contact sont nécessaires, utilisez des outils appropriés et / ou utilisez des gants de soudure lourds et isolés et des vêtements pour éviter les brûlures..



### **Le métal volant ou la saleté peut blesser les yeux**

- Lorsque le soudage, l'écaillage, le broyage des fils et le broyage peuvent provoquer des étincelles et du métal volant. Cela peut nuire à vos yeux.
- N'oubliez pas de porter des lunettes de sécurité appropriées avec des boucliers latéraux en zone de soudure, même sous votre casque de soudure.



### **Le bruit peut endommager l'audition**

- Le bruit peut provenir de certains équipements ou procédés de travail, utiliser une protection auditive approuvée pour protéger les oreilles si le niveau de bruit est élevé.



### **Les pièces en mouvement peuvent blesser.**

- Les pièces mobiles telles que les ventilateurs, les rotors et les ceintures peuvent causer de graves dommages à votre corps.
- Faites attention à vos doigts lorsque vous utilisez, restez loin des points de pincement tels que les rouleaux d'entraînement..
- Gardez toutes les portes, les panneaux, les couvercles et les gardes fermés et solidement en place.
- N'utilisez que des personnes qualifiées pour enlever les portes, les panneaux, les couvercles ou les protections pour l'entretien et la maintenance. Réinstallez les portes, les panneaux, les couvercles ou les protections lorsque l'entretien et la maintenance sont terminés et avant de reconnecter la puissance d'entrée



### **Une utilisation excessive peut entraîner une surchauffe**

- Une utilisation excessive peut endommager la machine, suivre le cycle de service pour utiliser la machine..
- Réduisez le courant ou réduisez le cycle de service avant de recommencer à souder.
- Permettre la période de refroidissement. Ne bloquez pas le débit d'air à l'unité..



### **La statique peut endommager les PCB**

- Toujours porter des poignets avant de toucher des PCB ou des pièces.
- Utilisez des sacs et un paquetage à l'épreuve de la statique pour stocker ou déplacer des PCB.



### **Marquages de sécurité**

- L'équipement avec marquage CE répond aux exigences de base de la directive sur la compatibilité basse tension et électromagnétique (par exemple, les normes de produit pertinentes selon EN 60974).



### **Marquages de sécurité**

- L'équipement avec les marques CCC répond aux exigences des règles de mise en œuvre pour la certification obligatoire en Chine.



### **Marquages de sécurité**

- Ce marquage signifie que le produit est certifié pour les marchés américain et canadien, conformément aux normes américaines et canadiennes applicables. L'emplacement préféré des indicateurs est comme indiqué.

## Contents

<b>1- GENERAL REMARKS</b> .....	<b>9</b>
1-1 Power source features.....	9
1-2 Functional principle.....	9
1-3 Output characteristics.....	9
1-4 Duty cycle.....	10
1-5 Applications.....	11
1-6 Warning label.....	11
<b>2-VERSIONS BRIEFS</b> .....	<b>12</b>
<b>3-BEFORE COMMISSIONING</b> .....	<b>12</b>
3-1 Utilization for intended purpose only.....	12
3-2 Machine installation rules.....	12
3-3 Power source connection.....	12
3-4 Welding cables instruction.....	12
3-5 Installation.....	13
3-6 welding process installation.....	15
<b>4 – PoWer SAW 1000 AC / DC (TANDEM)</b> .....	<b>18</b>
4-1 System components.....	18
4-2 Basic equipment for welding.....	18
4-3 Control panel.....	19
4-4 Interface.....	21
4-5 Sub menu.....	22
4-6 Technical data.....	24
4-7 Dimension.....	24
4-8 Disassembly and reassembly.....	25
<b>5-TROUBLE SHOOTING</b> .....	<b>27</b>
<b>6-CARE AND MAINTENANCE</b> .....	<b>29</b>

# 1- GENERAL REMARKS

This series power supply applies IGBT soft switch technology, enjoy reasonable static characteristic and sound dynamic characteristic. The power sources have high reliability of anti-fluctuation of power grid and perfect welding performance, is new type of high-efficiency energy-saving equipment.

## 1-1 Power source features

Highlights as follows:

- DSP control technology, realize digital control of welding process, improve control precision.
- Apply IGBT soft switch inverter technology, ensure a highly stable welding current against the fluctuation of network voltage and changes in arc length, arc has strong self- adjustment ability.
- High successful rate of arc starting.
- Drooping characteristic;
- It can perform carbon arc air gouging and AC-SAW welding mode;
- Wide range of current adjustment;
- Small size, light weight, flexible adjustment and convenient operation;
- High power factor, high-efficiency, energy-saving equipment.

## 1-2 Functional principle

This series of power sources adopt IGBT soft switch inverter technology to improve the dynamic response rate and make the machines with small size and light weight. The control circuit's closed-loop control makes the power source enjoy strong ability against power grid fluctuation and perfect welding performance.

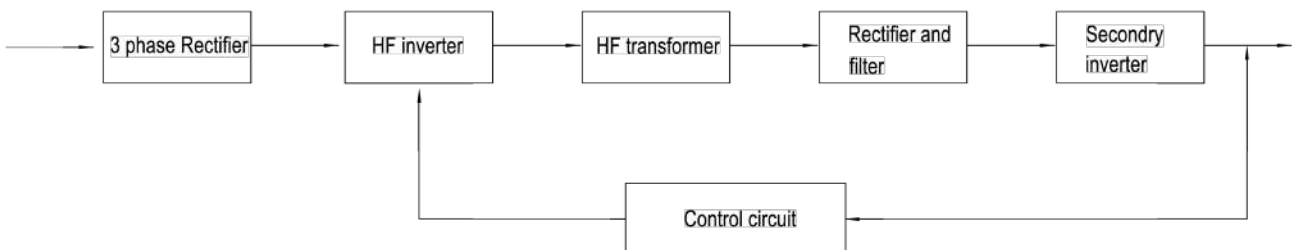

Fig.1-2-1: Schematic diagram

## 1-3 Output characteristics

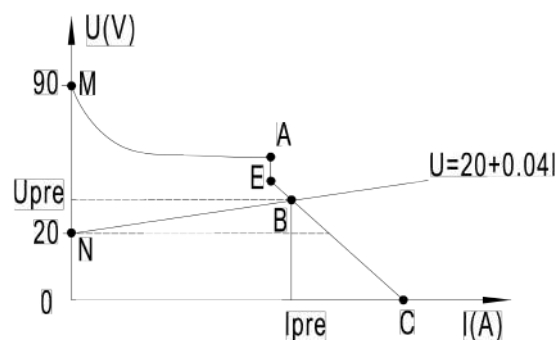

Fig.1-3-1: SAW mode volt-ampere curve

1.Volt-Ampere curve illustration on SAW mode

ASAW has flat characteristic and droop characteristic:

Droop characteristic:

M-A-D-C is Volt-Ampere static curve on SAW mode;

N-B is load curve;

Welding current is in accordance with the distance between B and ordinate axis.

Flat characteristic :

M-A is Volt-Ampere static curve on SAW mode;

N-B is load curve;

Welding voltage is in accordance with the distance between A and abscissa axis.

2. Volt-Ampere curve illustration on SMAW mode

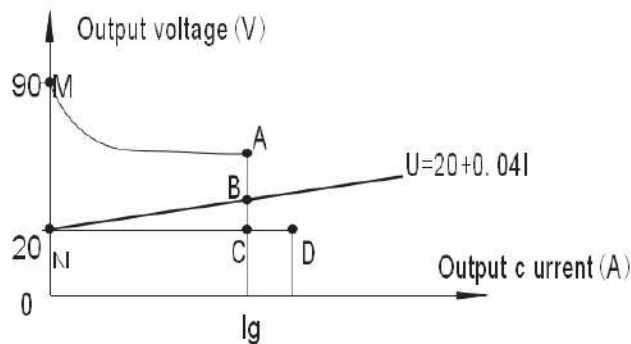

Fig.1-3-2: SMAW mode volt-ampere curve

M-A-B-C-D is Volt-Ampere static curve on SMAW mode;

N-B is load curve;

Welding current is in accordance with the distance between B and ordinate axis;

Arc force current is in accordance with the distance between C and D in the Volt-Ampere curve.

**1-4 Duty cycle**

Duty cycle is percentage of 10 minutes that a machine can weld at rated load without overheating. If overheats, thermostat(s) will open, output stops. Wait for fifteen minutes for the machine to cool down. Reduce amperage or duty cycle before welding.



**Note!** Exceeding duty cycle can damage the machine and greatly reduce its lifespan.

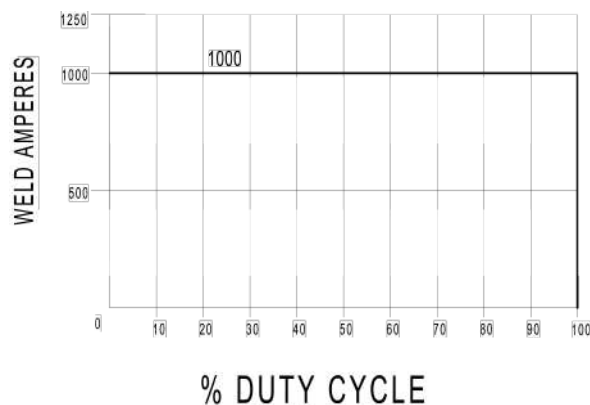

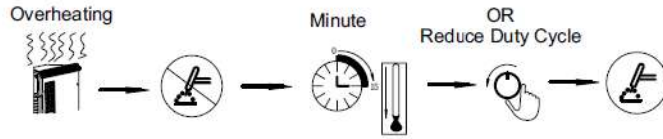

Fig.1-4-1: Duty cycle

## 1-5 Applications

Suitable for welding: carbon structural steel, stainless steel, heat resistant steel, and alloy steel.

The power source is designed for the following recommend areas:

- Vehicle manufacturing
- Chemical container manufacture
- Boiler pressure vessel manufacture
- Shipbuilding and offshore engineering
- Electric power construction
- Crane industry
- Mechanical industry
- Other industries

## 1-6 Warning label

The warning label is affixed on the top of machine.

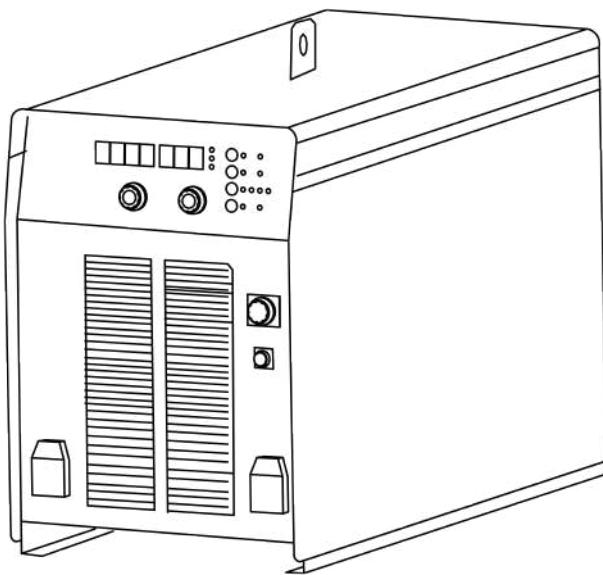

<b>! DANGEROUS! ! WARNING!</b>		<b>DO NOT REMOVE THIS MARKING</b>	
	<ul style="list-style-type: none"> <li>● ELECTRIC SHOCK can kill.</li> <li>● Keep the welder and work piece in good grounding.</li> </ul>		<ul style="list-style-type: none"> <li>● GASES AND FUMES can be dangerous &amp; hazardous to your health.</li> <li>● Keep adequate ventilation, anti-dust and exhaust.</li> <li>● Keep your head out of the fumes.</li> </ul>
	<ul style="list-style-type: none"> <li>● ARC RAYS, Spatter can injure eyes and skins.</li> <li>● NOISE can cause permanent hearing loss.</li> <li>● Wear protective clothing and welding shield with filter.</li> </ul>		<ul style="list-style-type: none"> <li>● FIRE, EXPLOSION can be caused by hot slag, spatter and sparks.</li> <li>● Remove combustibles from working area.</li> <li>● Provide fire watch as well as fire appliance in the working area.</li> </ul>

Fig. 1-6-1: Warning label

## 2-VERSIONS BRIEFS

Professional welding of special materials requires special welding parameters. Different models of the power sources are matched to different welding.

### ● PoWer SAW 1000 AC / DC (TANDEM)

The power source has logical arranged control panel for convenient operation, which can perform SAW, and SMAW. It has AC square wave submerged arc welding characteristic. Welding cable can be extended to 50m.

## 3-BEFORE COMMISSIONING



**Warning!** Operating the equipment incorrectly can cause serious injury and damage. Do not use the functions described here until you have read and completely understood "safety rules".

### 3-1 Utilization for intended purpose only

The power source may only be used for SAW, SMAW and GOUGING, Utilization for other purposes, or in any other manner, shall be deemed to be "not in accordance with the intended purpose". The manufacturer shall not be liable for any damage resulting from such improper use. Operate, inspect and maintain should follow all the instructions given in this manual.

### 3-2 Machine installation rules

According to test, protection degree of this power source is IP21S. However, the internal key components must be protected from direct soaking.



**Warning!** A machine that topples over or falls from its stand can cause injury. Place equipment on an even, firm floor in such a way that it stands firmly.

The venting duct is very important for safety protections. When choosing the machine location, make sure it is possible for the cooling air to freely enter and exit through the louvers on the front and back of machine. Any electro conductive metallic dust like drillings must not be allowed to get sucked into the machine.

### 3-3 Power source connection

- The power source is designed to run on the voltage given on the nameplate.
- The mains cables and plugs must be mounted in accordance with the relevant technical standards.
- The power supply sockets that come with power source are designed to use strictly according to the marked voltages.



**Note!** Inadequately dimensioned electrical installations can lead to serious damage. The mains lead, and its fuse protection, must be dimensioned in accordance with the local power supply. The technical data shown on the nameplate shall apply.

### 3-4 Welding cables instruction

When welding, please pay attention to the followings:

- a. The welding cables should be kept as short as possible.

b. If extended cable is used, please do as shown in Fig. 3-4-1.

<p style="text-align: center;"><b>Wrong</b></p> <p>Coil the excess ground cable and welding cable in same direction respectively.</p>	
<p style="text-align: center;"><b>Correct</b></p> <p>Straighten the ground cable and welding cable and make them close to each other.</p> <p>Bundle the ground cable and welding cable together, running the wires close to the ground.</p>	
<p style="text-align: center;"><b>Correct</b></p> <p>When the excess cables are only be used by rolling up, coil the cables to two windings in reverse direction and overlap them.</p> <p>The number of turns for A is same as the number for B.</p> <p>Handle the welding cable and ground cable according to above-mentioned method.</p>	

Fig. 3-4-1: Welding cables instruction

### 3-5 Installation

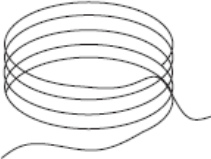
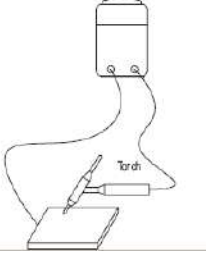
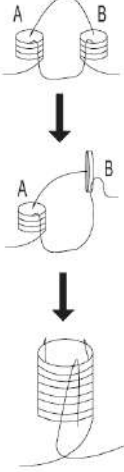

**Warning!** An electric shock can be fatal. If the machine is plugged into the mains electricity supply during installation, there is high risk of very serious injury and damage. Do not use the functions described here until you have read and completely understood “safety rules” in the beginning. Only carry out work on the machine when

- the mains switch is on turn-off position,
- the machine is unplugged from the mains.

• **Installation environment requirements**

1. It should be placed indoors without direct sunlight, rainproof, low humidity and less dust. The ambient air temperature range is -10°C~+40°C.
2. The inclination to the ground should not exceed 10°.
3. There should be no wind in the welding station, if any, it should be covered.
4. The welding machine is more than 20cm away from the wall, and the distance between the welding machine is more than 10cm.
5. When using water-cooled welding torch, pay attention to anti-freezing.

• Power supply and cable requirement

Model		1000
Power supply		3~AC380V/400V±10%, 50Hz
Min. power capacity (KVA)	Power network	83
	Generator	110
Input protection (A)	Fuse	90
	Circuit breaker	120
Min. cable size (mm <sup>2</sup> )	Power cord	16
	Output cable	70×2
	Protective GND wire	16

Table3-5-1: Power supply and cable requirement

Please note the size of fuse and circuit breaker in the table below are for reference only.

**Note!** Welding machine must be taken special design if it is powered by generator, please contact with manufacturer if you have such needs.

• connections of Power cord and distribution box



**Warning!** -Avoid hot-line work

- Operating by professional electrician
- Avoid connecting two power sources to one breaker
- Please refer to Table 3-5-1 to check if standard of input voltage, breaker and input cable is suitable

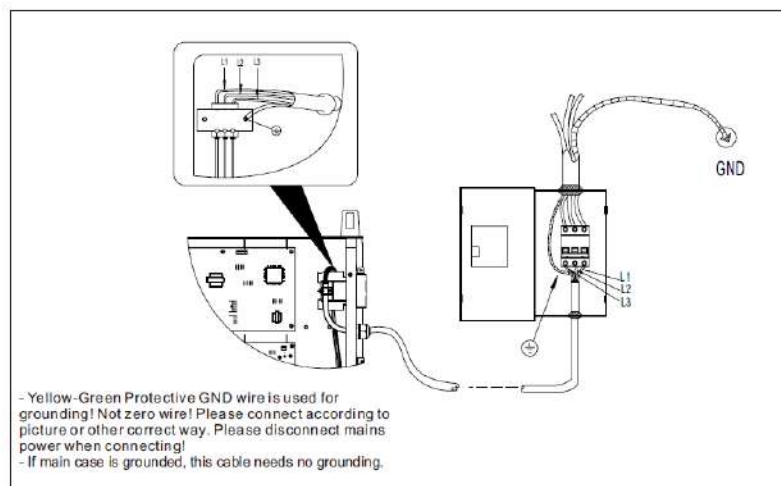

Fig. 3-5-2: Connections of power cord and distribution box



### 3-6 welding process installation



**Warning!** Operating the equipment incorrectly can cause serious injury and damage. This part is about operating. Do not use the functions until you have read and completely understood content of this manual.

#### •SAW-single wire welding process installation

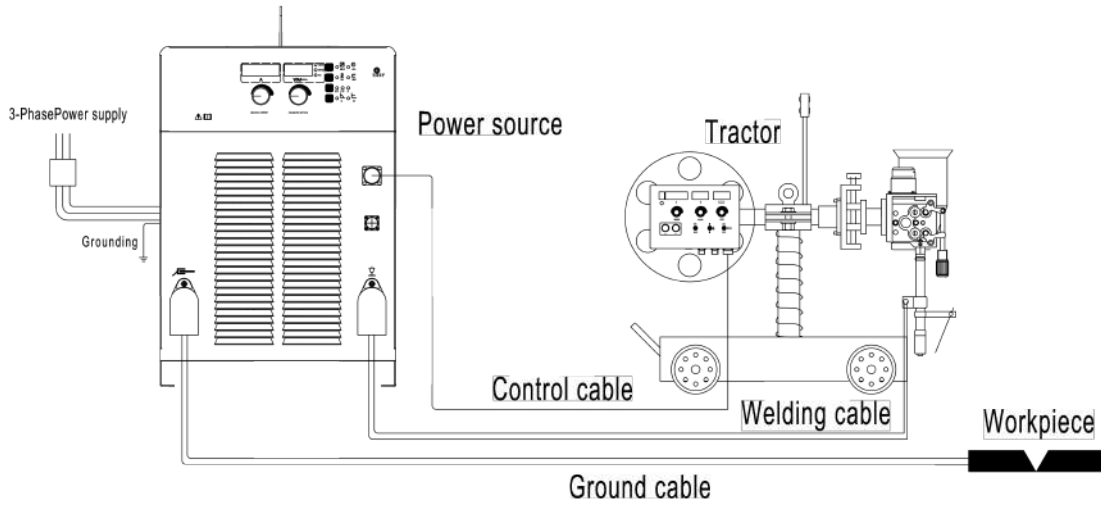

Fig. 3-6-1: Installation for SAW

#### •SAW-tandem(twin wire twin arc)welding process installation

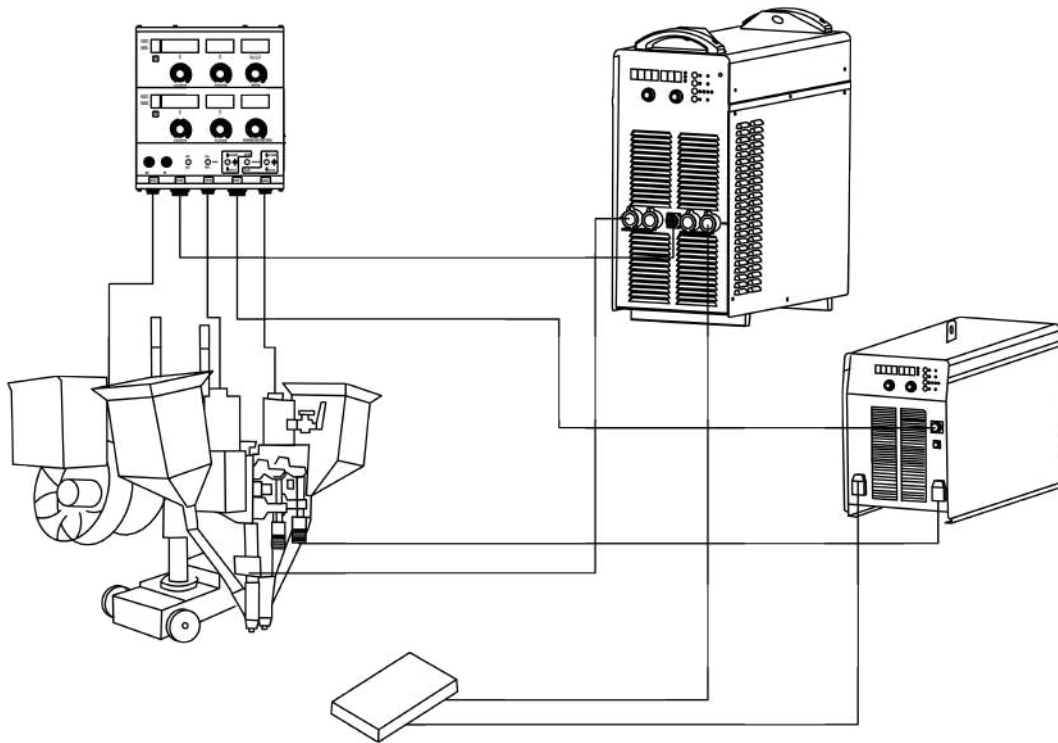



Fig. 3-6-2: Installation for SAW-Tandem

1. Complete the connection between the welding machine and the tractor according to Figure 3-6-2, and select the contact tip corresponding to the welding wire. power on.
2. Press the "Gouging/SAW" button and select the  " (SAW) state.
3. Press the "Welding Polarity" selection button, select the "AC" state, and adjust the AC frequency, duty cycle, and offset parameters according to welding requirements.
4. Refer to the control box instruction manual to adjust the welding parameters, and then perform welding.

5. Brief description of the influence of AC parameters on welding

A: AC frequency

Lowering the frequency can increase the penetration, with less energy input, but the arc is unstable; increasing the frequency can get a more stable arc, but with a shallower penetration. The relationship between AC frequency and penetration is shown in Figure 4-7-3.2.

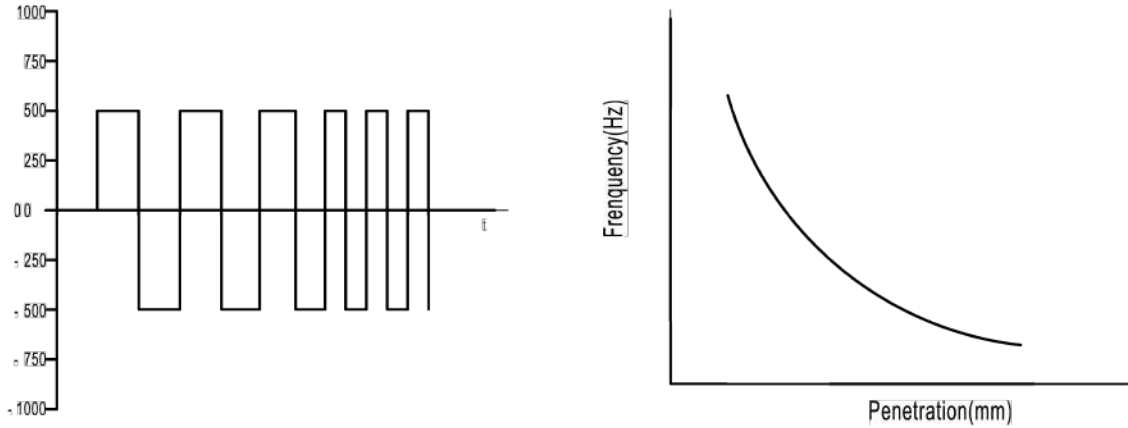

Fig. 3-6-3:AC frequency and penetration

B: AC duty cycle

The proportion of the forward current in the AC cycle (duty cycle) can adjust the welding penetration and cladding rate; the larger the duty cycle, the deeper the penetration, and the smaller the cladding rate; the smaller the duty cycle, the penetration shallower, the greater the cladding rate. The relationship between AC duty cycle and penetration is shown in Figure 4-7-4.

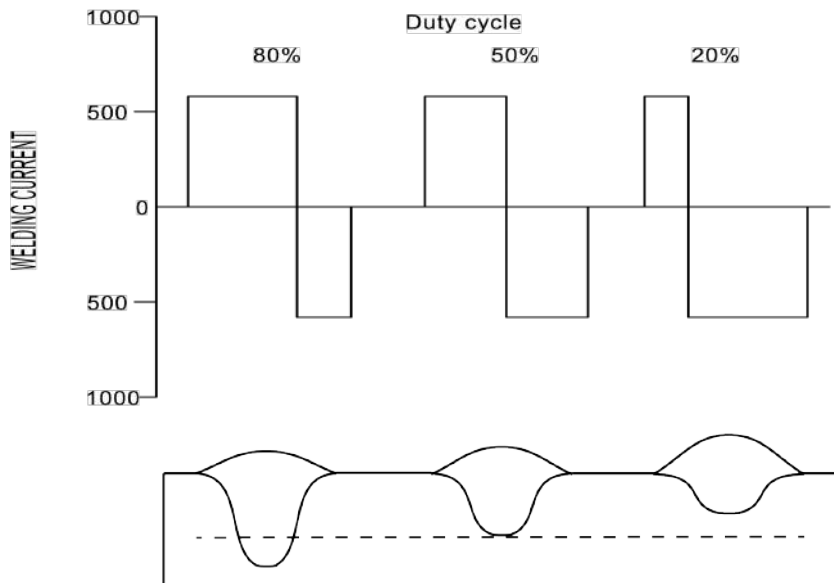

Fig.3-6-4.AC duty cycle and penetration

C: AC bias

Adjusting the AC bias of the AC current can adjust the welding penetration and cladding rate; increase the AC positive bias, increase the penetration depth and reduce the cladding rate; increase the AC negative bias, reduce the penetration depth, and increase the cladding rate. The relationship between AC bias current and penetration is shown in Figure 4-7-5.

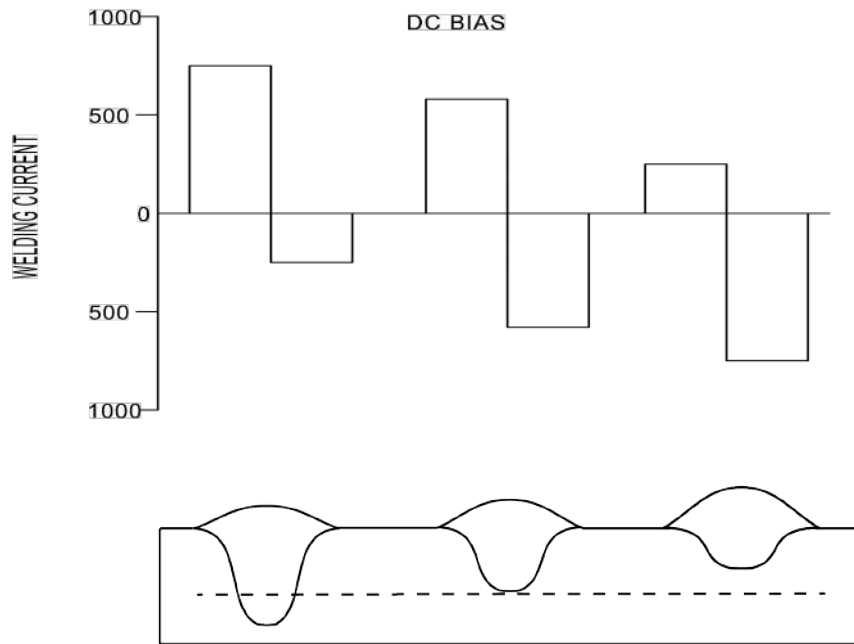

Fig 3-6-5: AC bias and penetration and cladding rate

• SMAW(STICK) welding process installation

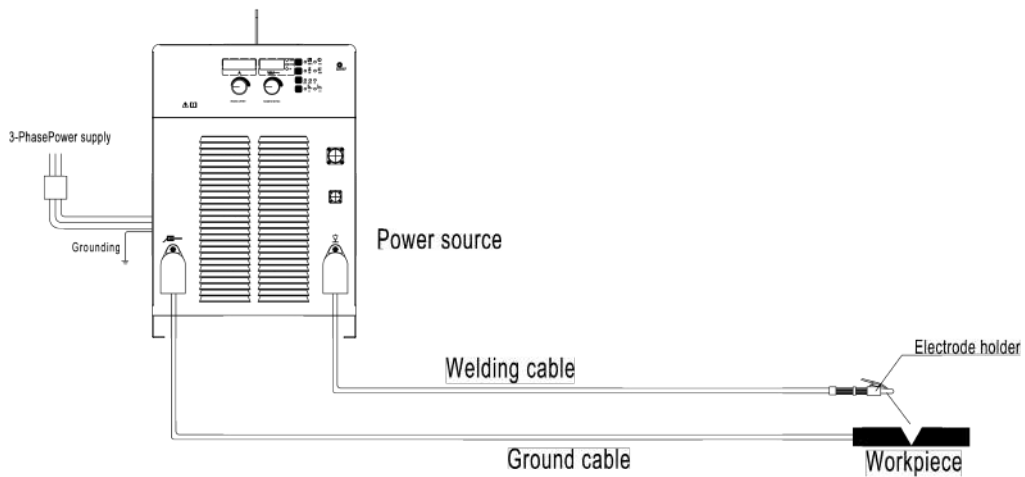

Fig. 4-7-2: Installation for STICK

• GOUGING process installation

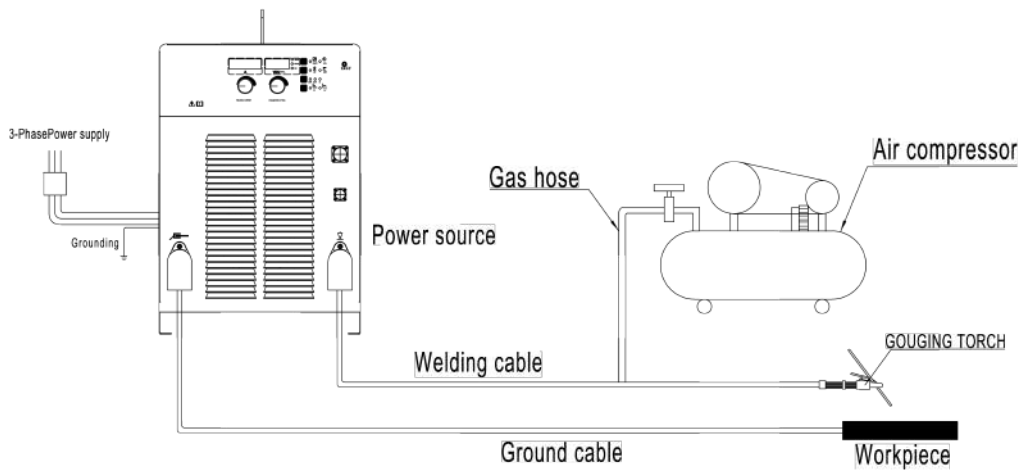

Fig. 4-7-4: Installation for GOUGING

## 4-PoWer SAW 1000 ACDC

### 4-1 System components

This welding machine can be equipped with many different accessories and can be used in different special sites with different configurations.

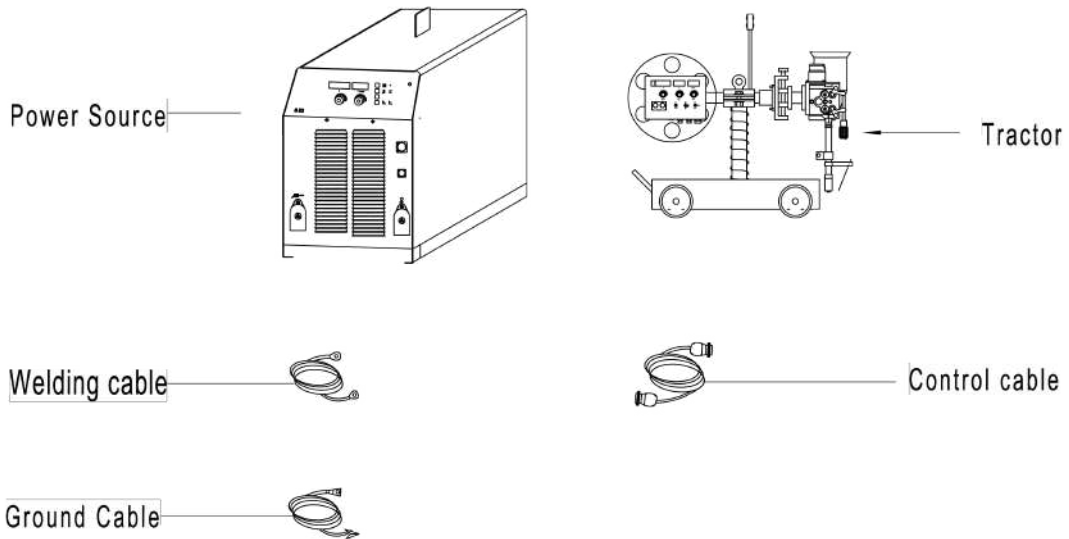

Fig. 4-1-1: System components

### 4-2 Basic equipment for welding

Only be equipped with the necessary accessories, can the power source operate well. The following is the needed accessories list.

### SAW welding

- Power source
- Ground cable
- Welding cable
- Control cable
- SAW tractor
- Wire
- Flux

### GOUGING cutting

- Power source
- Ground cable
- Gouging torch
- Carbon rod
- Air compressor

### SMAW welding

- Power source
- Ground cable
- Electrode holder
- Electrode

## 4-3 Control panel

The functions on the control panels are all arranged in a very logical way. The various modes and parameters needed for welding are easy to select by pressing the appropriate button; parameters are easy to be adjusted by rotating encoder. Synergic adjustment makes the complicated operation much easier.



**Note!** Some described parameters in this manual may be slightly different from the power source, some identification may be slightly different from power source identification, but the manner of working is the same.



**Warning!** Operating the equipment incorrectly can cause serious injury and damage. Do not use the functions described here until you have read and completely understood all content of this manual.

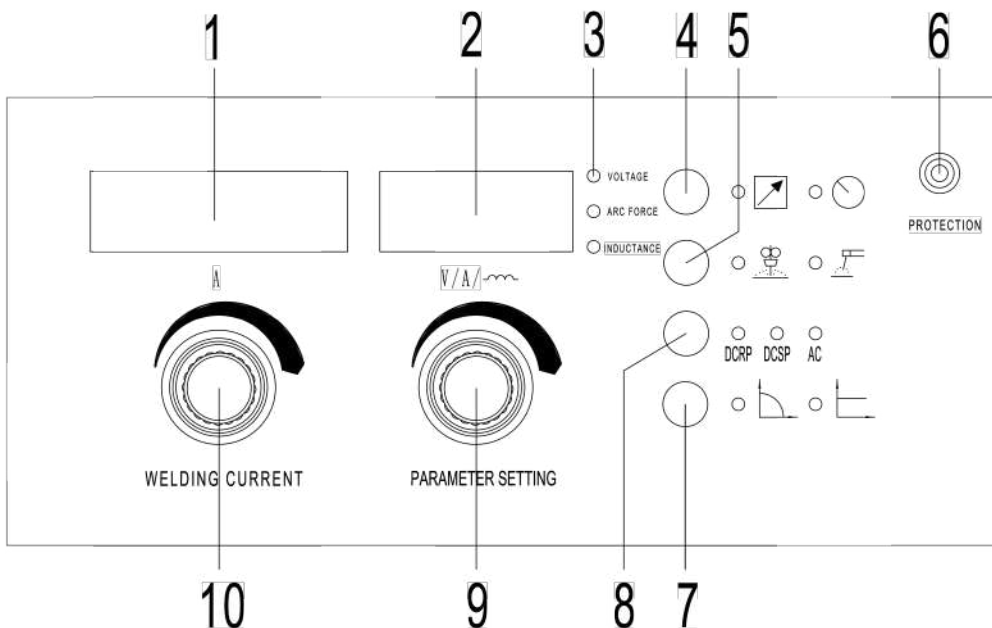

Fig. 4-3-1: Control panel

#### 1." A" displayer

On standby mode, display the preset current.

When welding machine has output current, display actual welding current.

On welding machine parameter adjustment mode, display parameter no..

#### 2.Arc voltage/ Arc force/ Inductance displayer

During SAW mode: On standby mode, display the preset voltage value of welding machine; when welding, display actual voltage value of welding machine; when frequency, duty cycle or AC bias indicator lights up, display AC frequency, AC duty cycle or AC bias.

During SMAW mode: Display actual voltage of welding machine; when adjust arc force adjustment knob, display preset arc force value shortly.

On welding machine parameter adjustment mode, display prepared to be adjusted parameter or setting value.

#### 3.Frequency/ Duty cycle/ Bias indicator

It lights up means right displayer displays AC frequency, AC duty cycle or AC bias; press parameter adjustment knob to choose frequency, duty cycle or AC bias, rotate parameter adjustment knob to adjust corresponding parameter.

Only can adjust AC parameter when welding machine is on AC output mode.

#### 4. "Remote /Panel control" button

Remote control mode , adjust welding current by SAW tractor control box;

Panel control mode , adjust welding current on the welding machine control panel.

#### 5. "SMAW / SAW" button

Position  (SMAW), SMAW or Gouging mode;

Position  (SAW), SAW mode.

#### 6.Over-load protector

When the armature current of the wire feed or carriage motor and the excitation current of the wire feed motor are too large, the overload protector turns off, the welding machine stops working, the control box is powered off, and the welding machine displays E43 code; when the motor and connection failure are eliminated After pressing and restoring the overload protector, the welder can continue to work.

#### 7.Reserved button

Reserved SAW function button. Now welding machine only supports drooping characteristic SAW, "" (drooping characteristic) indicator lights up, SMAW mode, indicator lights off.

#### 8.Output polarity selection button

"DCRP", The positive output terminal of the welding machine is connected to the electrode of the trolley, and the negative output terminal of the welding machine is connected to the workpiece.

"DCSP", The positive output terminal of the welding machine is connected to the workpiece, and the negative output terminal of the welding machine is connected to the electrode of the trolley;

"AC", The positive output terminal of the welding machine is connected to the electrode of the trolley, and the negative output terminal of the welding machine is connected to the workpiece.

This button functions on SAW mode only, when on SMAW mode, indicator lights off.

#### 9.Parameter adjustment knob

During SMAW mode , adjust arc force current, adjustment range is 0~200A;

During SAW, AC output mode, adjust frequency, duty cycle and AC bias;

On welding machine parameter adjustment mode, it is used to adjust parameter or setting.

#### 10.Welding current adjustment knob

When in "Panel Control" , adjust the welding current, adjustment range is 50~1010A;

On welding machine parameter adjustment mode, it is used to choose parameter or setting.

## 4-4 Interface

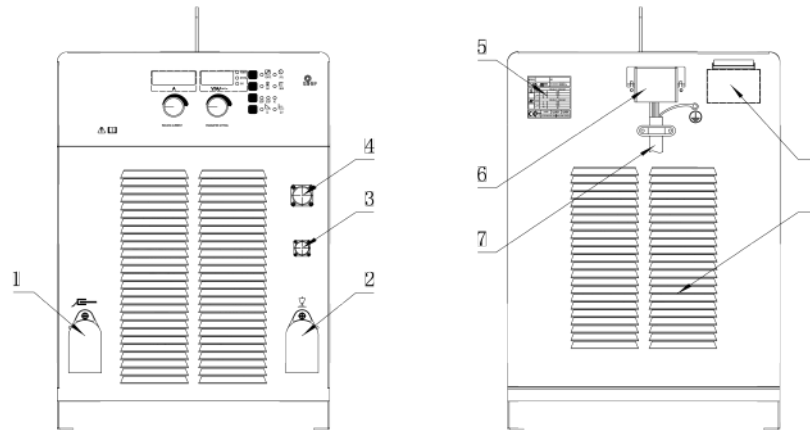

pin	Description	Signal type	value
1~2	Wire feeding motor armature	Analog DC	10-110VDC
3~4	Tractor travelling motor armature	Analog DC	10-110VDC
5~6	Wire feeding motor excitation	Analog DC	110-130VDC
7	SAW arc voltage feedback signal (get from the tractor head)	Analog DC	Welding voltage&OCV
8~9	485 communication interface between welding machine and the tractor	Digital	Control box to welding machine
10-11	485 communication interface between welding machine and the tractor	Digital	welding machine to Control box
12~14	Null		

Fig. 4-4-1: interface

### 1.Negative output terminal (-)

Connect with work piece by ground cable

### 2.Positive output terminal (+)

SAW mode: connect with SAW tractor by welding cable (+); SMAW mode: connect with electrode holder;

GOUGING: connect with gouging torch.

### 3.Synchronous Control socket

In multi-wire welding, the synchronous cable is used to connect the synchronous cable sockets of other AC welding machines to realize the synchronous work of multiple welding machines.

### 4.Tractor control socket

Connect with tractor control box by control cable, provide power supply for tractor control box, transmit control signal and feedback arc voltage.

Table. 4-4-1: control socket

### 5.Nameplate

### 6.Power cord connecting box

For connecting AC 3-phase power supply.

### 7.Power cord

Three-phase four-wire system, yellow-green wire connection ground.

To ensure operators not being harmed and welding machine working normally, make sure the earthing bolt is grounded firmly by ground cable.

### 8.Fan

Cool down the heat components in the welding machine.

### 9.Circuit breaker

The function of circuit breaker is to protect welding machine and operator by automatic trip to turn-off power

supply when overload or short circuit happens to the power source. Normally, the switch flipped to upward means power-on. To start or stop the welding machine is done by the mains switch in the distribution box. Please do not take this circuit breaker as the power switch.

#### 4-5 Sub menu

Code	Item	description	Setting range	Unit	Factory setting
P00	Hot start current	When the success rate of arc starting is low, the arc starting current can be increased.	100~400	A	200
P01	Initial arcing voltage	Welding voltage during the arc starting phase.	25.0~40.0	V	30.0
P02	The duration of Initial arcing voltage	The duration of the arcing phase.	0.1~0.5	s	0.2
P03	Reserved	--			
P04	Crater voltage	Welding voltage for arc filling.	25.0~40.0	V	30.0
P05	Crater time	The duration of arc filling welding voltage	0.1~10.0	s	2.0
P06	Burn back time	Press the stop button, after the wire feeder stops working, the welding machine continues to work. If the welding wire sticks to the workpiece at the end of welding, the burn back time can be increased.	0.1~2.0	s	1.0
P07	Wire diameter	Selection of welding wire diameter.	3.2、4.0、5.0	mm	4.0
P08	Manual wire feeding speed	Wire feeding speed when the wire feeding button is pressed without load.	20~80		50
P09	Slow wire feeding speed	Wire feeding speed before successful arc starting.	10~30		18
P10~P11	Reserved	--			
P12	MODBUS address number	The welding machine as a slave machine communicates with external devices via ModBus. This parameter is the address of the welding machine. If ModBus communication is not used, adjust this parameter to OFF.	OFF, 0~100		OFF
P13	Address number for multi-wire welding	The number of the welding machine in the double-wire double-arc welding system, "0" represents the master, and "1" represents the slave. When working alone, this parameter must be set to "0" (master).	0,1		0
P14	Wire feed motor selection	When the wire feed motor has an encoder, set it to On, and the wire feed motor without an encoder is set to OFF.	On、OFF		On
P15	Factory reset	Under this parameter, press and hold the welding current knob for 1 second, all parameters or settings will be restored to the factory default			



		values.			
--	--	---------	--	--	--

Table. 4-5-1: Sub menu parameters

### Sub menu setting

**enter the sub menu:** In the standby state, select local control, and simultaneously press and hold the welding current (left knob) and parameter set(right knob) knobs on the front panel of the welding machine for 5 seconds.

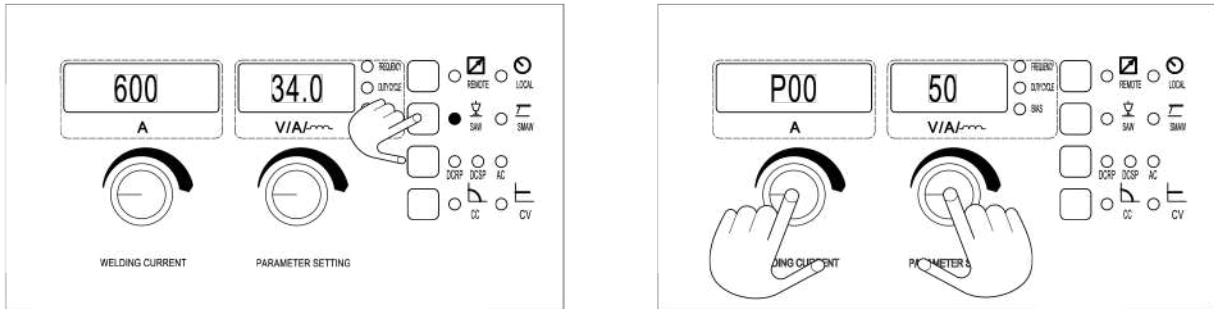

Fig. 4-5-1: enter the sub menu

**Parameter adjustment:** Turn the Arc force knob to select the P parameter, and turn the current knob to adjust the value of the parameter.

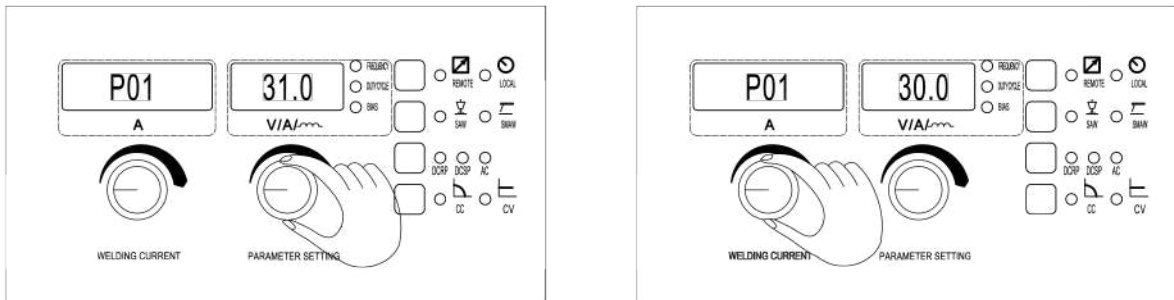

Fig. 4-5-2: parameter adjustment

**Exit sub menu:** In the sub-menu interface, Press and hold the "welding current knob" for 1 second, exit sub menu.

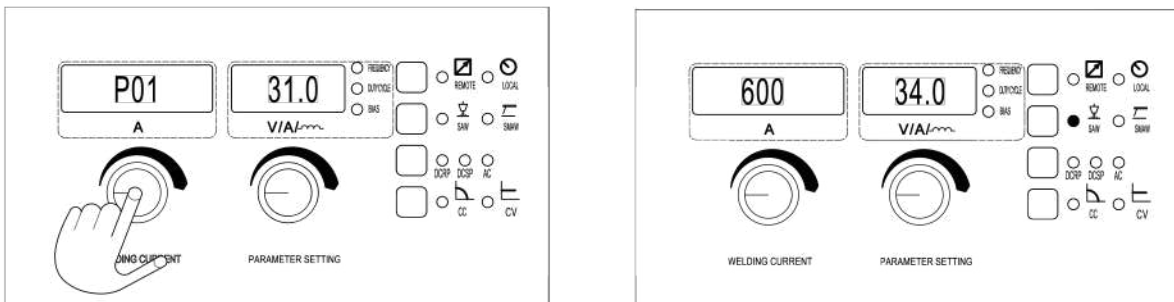

Fig. 4-5-3: Exit the sub menu

### 4-6 Technical data

Model	1000
Primary power voltage /Frequency	3 phase, AC380V/400V±10%, 50Hz
Rated input power (KVA)	55
Rated input current (A)	82/78
Welding current range (A)	60~1000
Welding voltage range (V)	22.4~40
Rated duty cycle (%)	100
Open circuit voltage (V)	90
Efficiency (%)	≥89
Power factor	≥0.95
Wire diameter (mm2)	Φ3.2~Φ5.0
Dimensions (mm3)	1040×500×720
Weight (Kg)	165
Insulation class	H

Table 4-6-1: Technical data

### 4-7 Dimension

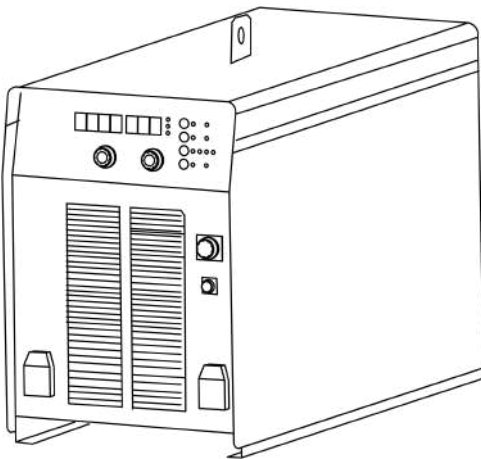

Fig. 4-7-1: Dimension

NO.	Item	Unit (mm)	Inches
1	length	1040	40.9
2	Width	500	19.7
3	Height	720	28.3

Table. 4-7-1: Dimension

## 4-8 Disassembly and reassembly

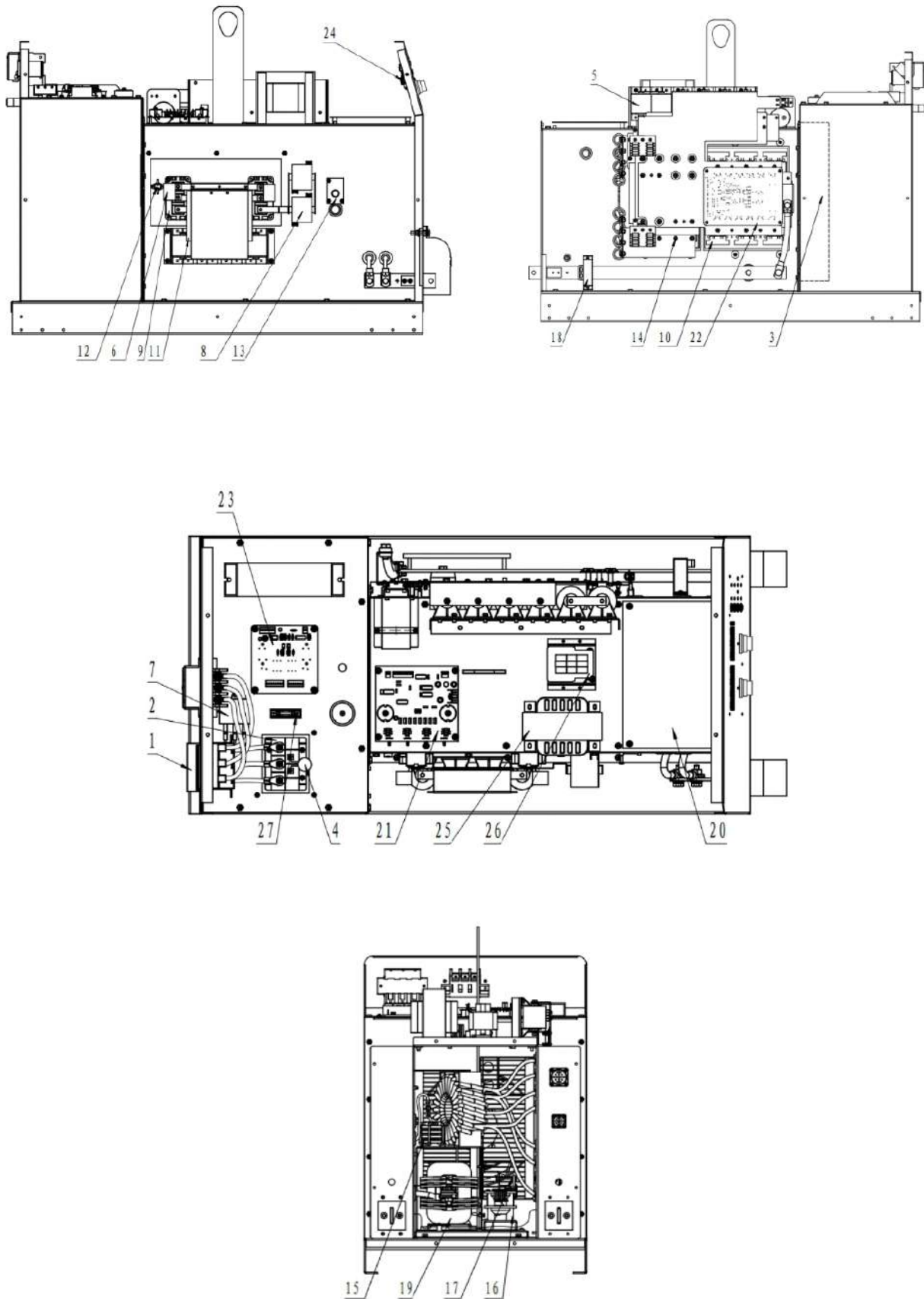

Fig. 4-8-1: Disassemble and reassembly

No	Item	Stock No.	Remarks
1	Circuit breaker	745011-00001	
2	Three phase rectifier module	735005-00008	
3	Fan	746002-00035	
4	Varistor	720021-00017	
5	Polypropylene capacitor	722001-00116	
6	Polypropylene capacitor	722001-00177	
7	Polypropylene capacitor	722001-00015	
8	Polypropylene capacitor	722001-00073	
9	IGBT module	735007-00119	
10	Secondary IGBT	220900-00234	
11	IGBT protection board	220005-00125	
12	Temperature relay	745008-00008	
13	Current transformer	220149-00122	
14	Fast recovery diode module	735006-00098	
15	Resonant inductor	220521-00065	
16	Current exchange inductor	220281-00033	
17	Commutating inductance	220287-00006	
18	Current sensor	753001-00057	
19	Reactor	763004-00165	
20	Main control board (with parameters)	210580-00844	
21	Drive board	210310-00020	
22	Secondary drive board	210310-00109	
23	Fan control board	210950-00090	
24	Digital display board	220383-00005	
25	Power transformer	763001-00043	380V
		763001-00051	400V CE
26	Power transformer	763001-00021	380V
		763001-00052	400V CE
27	Fuse	745007-00012	
		745007-00018	400V CE
28	Filter	752004-00017	400V CE

Table4-8-1: Main components list

## 5-TROUBLE SHOOTING



**Warning!** An electric shock can be fatal. Before doing any work on the machine:

-Switch it off and unplug it from the mains

-Put up a clearly legible and easy-to-understand warning sign to stop anybody inadvertently switching it on again

-Check to make sure the electrically charged components (e.g., Capacitors) have been discharged.

-Bolts in machine case also work for ground connection. Never use other bolt that cannot work for ground connection.



**Note!** The flowing troubles and causes are uncertain. However, during the normal using conditions, that might happen.

### Error code

This series welding machine will be on protected mode if machine has any problem, and display error code.

No.	Error code	Fault	Remedy
1	E19 Over-heat protection	1. Environment temperature is over 40 degree 2. Fan is damaged so that air volume decreases 3. Temperature relay is damaged so that it is normally open	1. Wait to cool down 2. Check or replace 3. Check or replace
2	E1E Secondary side over voltage protection	1. Leak resistor or capacitor is damaged 2. Cable is too long or coils 3. Main control board is damaged 4. Current transformer is damaged, current sensor is damaged	1. Check or replace 2. Shorten cable, remove coiled cable 3. Check or replace 4. Check or replace
3	E43 Communication fault	1. Control cable plug is loose or control cable is broken 2. Main control board is damaged	1. Fasten plug, check cable 2. Check or replace
4	E70 Short circuit issue when switch from SAW to SMAW	When switch to SMAW, welding machine output terminal has short circuit issue	Check whether there is short circuit between electrode holder or tractor head and work piece
5	E03 Fan is damaged	Wrong phase sequence of welding machine 3 phase power cord	Power off distribution board, exchange any two phase of 3 phase power cord
6	E30 Wire feeder motor is over load	External of wire feeder motor armature is short circuit, wire feeder is locked-rotator	Check and repair
7	E17 Output of welding machine is long time over load	1. Current transformer is damaged 2. Current sensor is damaged 3. Main control board is damaged	Check and replace

Table 5-1: Error code

**Machine problem, cause and remedy**

No.	Problem	Cause	Remedy
1	Welding machine does not work, fan does not run when welding	<ol style="list-style-type: none"> <li>1. Phase missing</li> <li>2. Fuse (2A) is broken</li> <li>3. Fan, power transformer, solid state relay or main control board is damaged</li> <li>4. Cable is broken</li> <li>5. Circuit breaker trips</li> </ol>	<ol style="list-style-type: none"> <li>1. Check</li> <li>2. Check and replace</li> <li>3. Check and replace</li> <li>4. Check</li> <li>5. Check IGBT module, three phase rectifier module. Note: drive board, IGBT module or three phase rectifier module may be damaged, need to replace</li> </ol>
2	Welding current is damaged	<ol style="list-style-type: none"> <li>1. Phase missing</li> <li>2. Current sensor is damaged</li> <li>3. Main control board is damaged</li> <li>4. Three phase rectifier bridge is damaged</li> </ol>	<ol style="list-style-type: none"> <li>1. Check power supply</li> <li>2. Check and replace</li> <li>3. Check and replace</li> <li>4. Check and replace</li> </ol>
3	Welding current is damaged	<ol style="list-style-type: none"> <li>1. Phase missing</li> <li>2. Current sensor is damaged</li> <li>3. Main control board is damaged</li> <li>4. Three phase rectifier bridge is damaged</li> </ol>	<ol style="list-style-type: none"> <li>1. Check power supply</li> <li>2. Check and replace</li> <li>3. Check and replace</li> <li>4. Check and replace</li> </ol>

Table 5-2: Machine problem, cause and remedy

## 6-CARE AND MAINTENANCE

- **Before open the machine**



**Warning!** An electric shock can be fatal. Before doing any work on the machine:

- Switch it off and unplug it from the mains.
- Put up a clearly legible and easy-to-understand warning sign to stop anybody inadvertently switching it on again.
- Check to make sure the electrically charged components (e.g. Capacitors) have been discharged;
- Bolts in machine case also work for ground connection. Never use other bolt that cannot work for ground connection.

- **Maintenance**

Please follow the instructions as below to ensure normal lifespan of power source.

- Conduct safety check at regular intervals (see “Safety rules”);
- Dismantle machine side panels and clean machine inside with clean and low-pressure compressed air by professional technician, not less than twice per year. Clean the components at a certain distance only;
- If a lot of dust has accumulated, clean the cooling-air ducts.

- **Daily maintenance**

			Disconnect main power before maintenance			
	3 months					
Change illegible label			Repair or replace broken cable		Clean and tighten welding terminal	
	6 months					
Blow or suck inner part, and clean every month when working in harsh environmental conditions		OR				

Fig. 6-1: Daily maintenance

# Power SAW Series



# GeKaMac®



**Gedik Welding Inc.**

Ankara Caddesi No: 306 Şeyhli 34906 Pendik - İstanbul / Turkey

**P.** +90 216 378 50 00 • **F.** +90 216 378 20 44

[www.gedikwelding.com](http://www.gedikwelding.com)